

Main Level

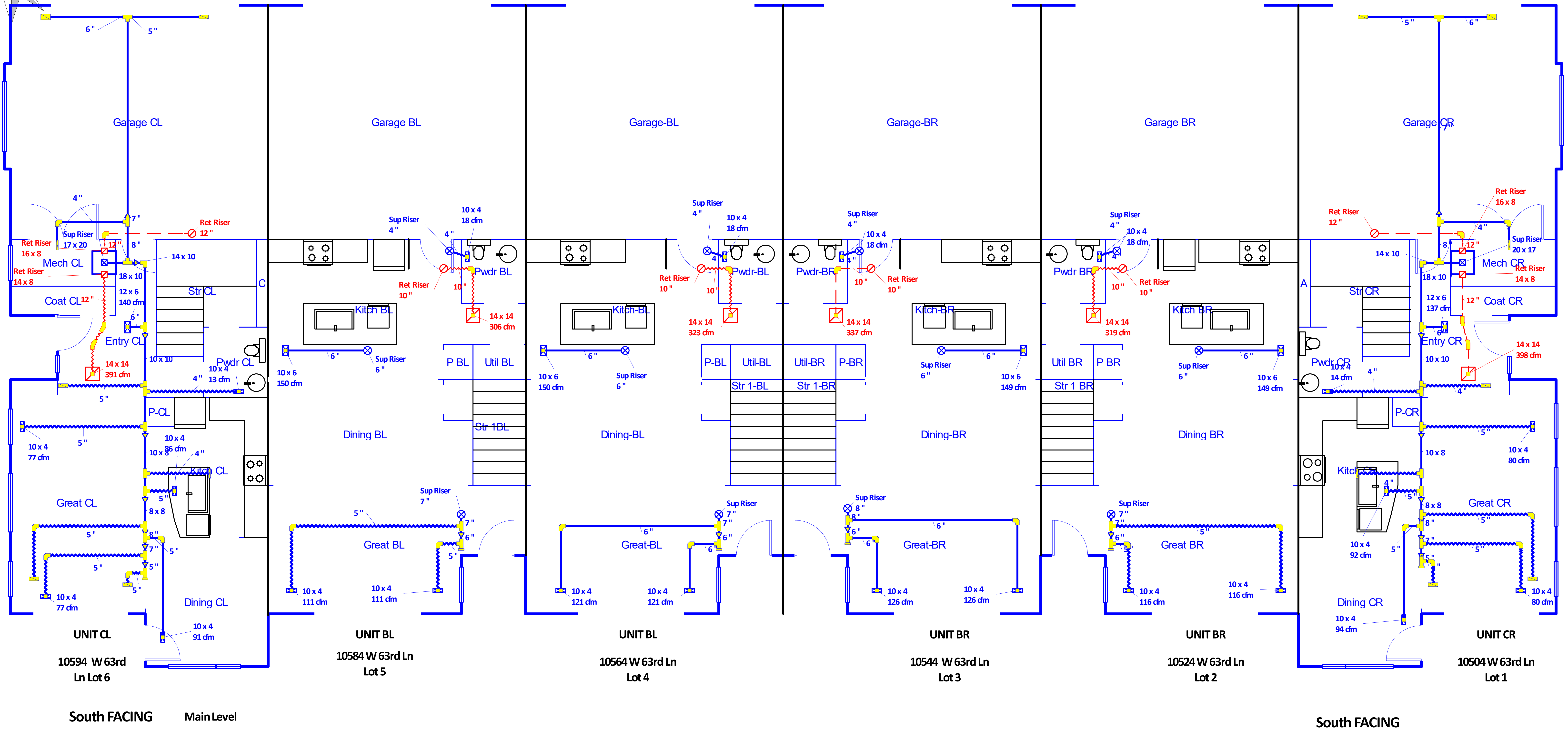

ALL DUCTS, EQUIPMENT AND LAYOUT SHOWN ARE DIAGRAMMATIC IN NATURE ONLY OFFSETS AND ADDITIONAL FITTINGS MAYBE REQUIRED, BUT ARE DISCOURAGED. THESE COULD CHANGE REQUIRED DUCT SIZES AND DUCT LAYOUT. ADDING OR CHANGING ANY DUCT MUST BE DONE IN ACCORDENCE WITH STANDARD PRATICES AND ACCA STANDARDS. KEEP CHANGES TO A MINIMUM. LOW LOSS FITTINGS ARE REQUIRED ALONG WITH TURNING VANES IN RECTANGULAR ELBOWS AND TEES.

<p>Job #: 21.21 Bldg 2 Type 2 Performed by Terry Moore 720-515-1714 for: Ralston Terrace II 10504, 10524, 10544, 10584, 10594 W 63rd Ln, Lot 1-6 Arvada, CO 80004 Phone: 303-475-4568 dcerniglia@creeksidecommunities.com</p>	<p>Indoor Air Quality Inc 12051 E Iowa Ave Aurora, CO 80012 Phone: 303-798-0500 pat@iaqcolorado.com</p>	<p>Scale: 1/4" = 1'0" Page 1 Right-Suite® Universal 2021 21.0.02 RSU00915 2021-Jun-04 21:12:40 ...Building 1 Typ 14 South Face.rup</p>
---	--	---

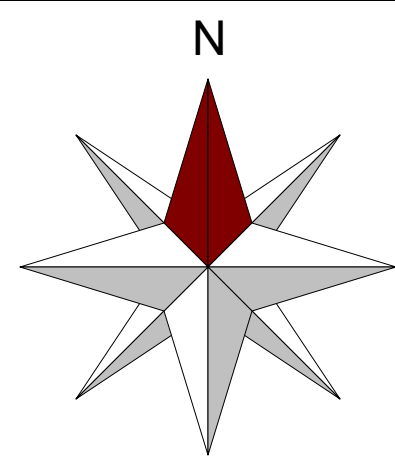

Second Level

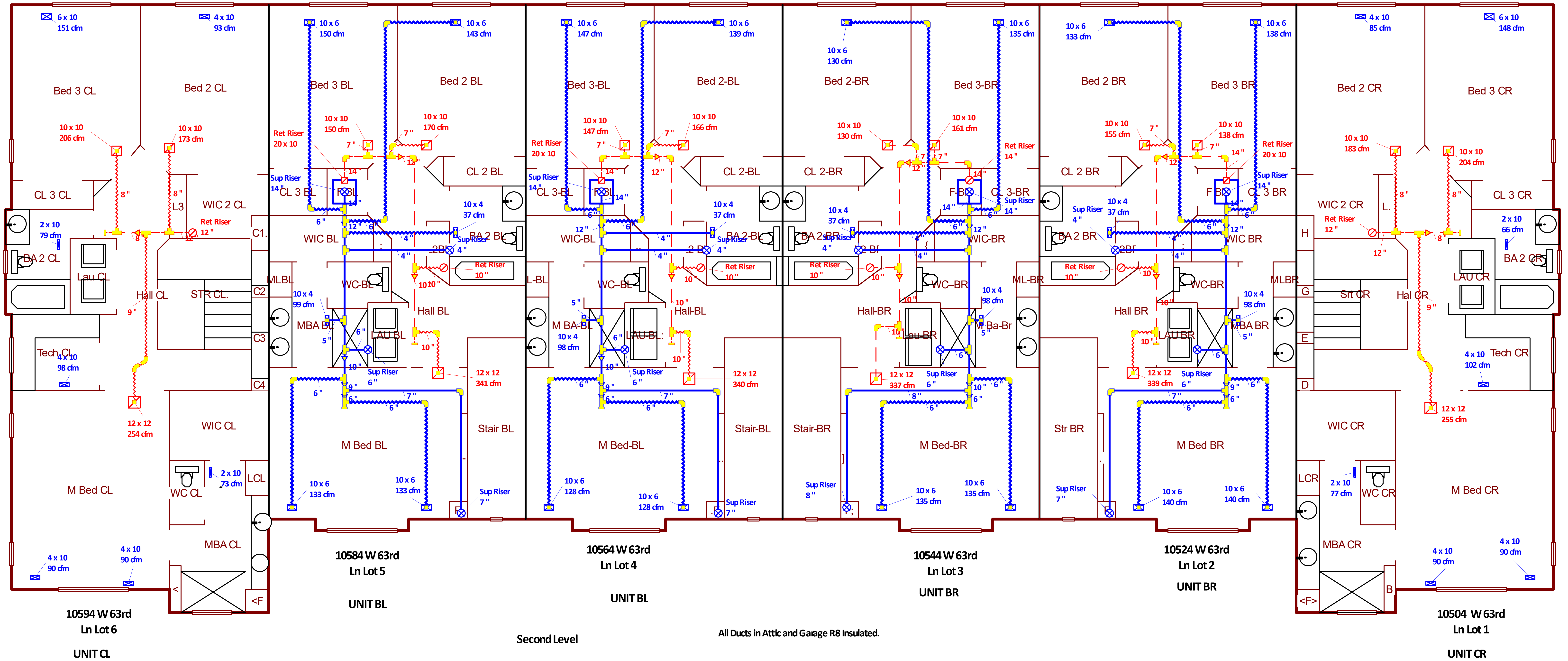

Job #: 21.21 Bldg 2 Type 2
Performed by Terry Moore 720-515-1714 for:
 Ralston Terrace II
 10504, 10524, 10544, 10584, 10594 W 63rd Ln, Lot 1-6 W 63rd
 Arvada, CO 80004
 Phone: 303-475-4568
 dcerniglia@creeksidecommunities.com

Indoor Air Quality Inc
 12051 E Iowa Ave
 Aurora, CO 80012
 Phone: 303-798-0500
 pat@iaqcolorado.com

Scale: 1/4" = 1'0"
 Page 2
 Right-Suite® Universal 2021
 21.0.02 RSU00915
 2021-Jun-04 21:12:40
 ...Building 1 Typ 14 South Face.rup